

**YOUR EXPERTS FOR  
MATERIAL HANDLING**

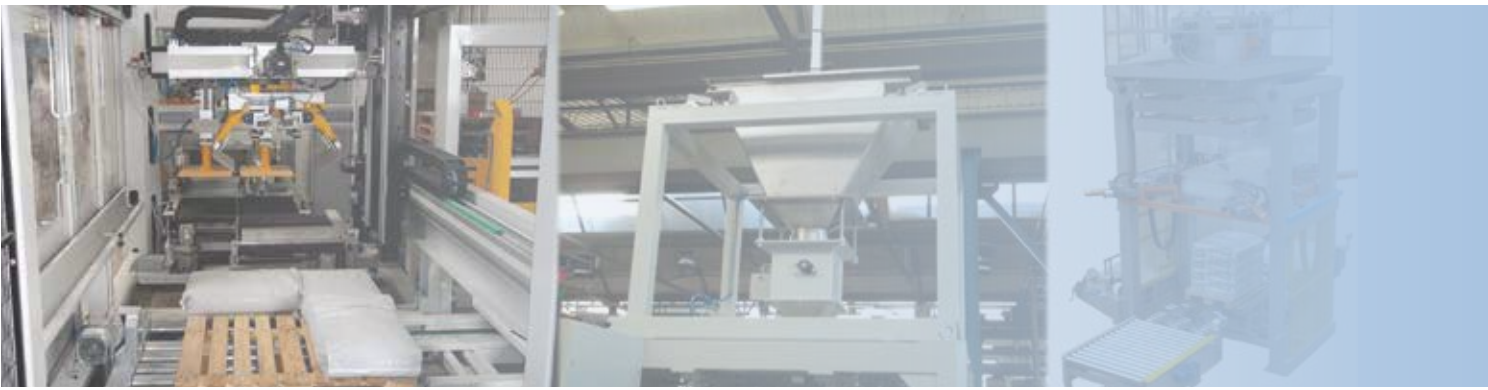



**Served  
Industry Verticals**

Fertilizers

Urea

NPK

Amonium Phosphate

Alum Granuals

Chemical and  
Petrochemicals

Plastic Granuals

Plastic Chips

Polysterene

Inert Solids

Food (Seeds &  
Grains)

Rice

Wheat Flour

Tea Powder

Animal Feed

Caster Oil Flakes

Lodized Salt

Soya DOC

## Complete Range of Material Handling Solutions



Jasubhai Engineering Pvt. Ltd. offers a complete range of all Material Handling Systems which come fully equipped with all the necessary Automation.

Our range of offerings starts with Silos/Hoppers, different types of Slide Gates and Diverter Valves, fully automatic microprocessor based controller operated Automatic Weighing and Bagging Systems, and extends to Automatic Bag Placers and Bag Pushers, Belt Conveyor Systems, Sealing Machines, Stitching Machines, Turn Tables, Online Check Weighers with Rejection Systems, Robot Palletizers and Truck loaders.

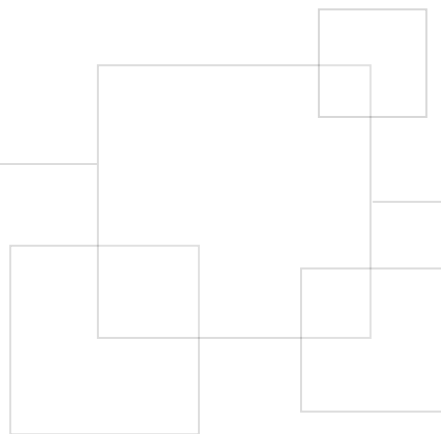



## Fertilizers, Plastic Granules, Food Processing & Animal Feed

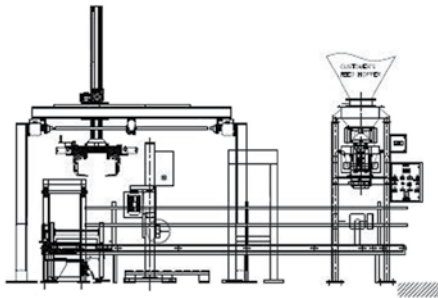

Elevation

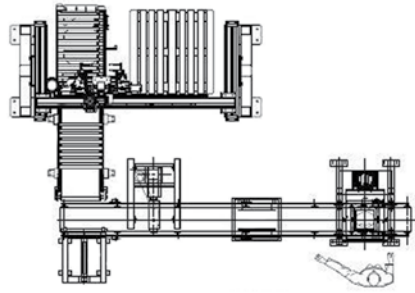

Plan View

Our microprocessor based semi-automatic machine automatically weighs and bags.

Once the bag is moved to the sealing and stitching station through the synchronized belt conveyor, the bag pusher changes the orientation of the bag and the conveyor delivers the bags to the gantry system.

The gantry palletizing system then stacks the bags automatically on the pallets in a predefined and programmed matrix.

After the completion of palletizing, the forklift comes and takes away the complete pallet.

## Food Processing & Animal Feed

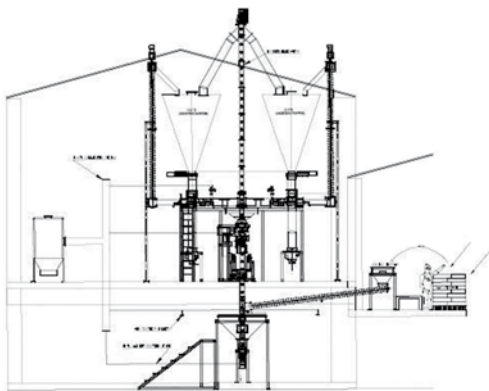

Elevation

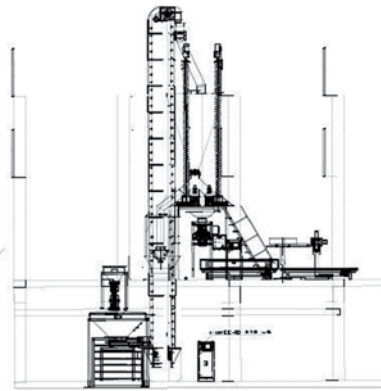

Side View

A Complete Automatic Weighing and Bagging System for powder animal feed additives consists of different types of Hoppers/ Silos, Screw Conveyors, Densifying Screw Conveyor, Bucket Elevator, Transition Chutes, Bin Vibrator, Pneumatic Slide Gates, Bagging Machine, Belt Conveyors, Pneumatic Conveying, Two Way Diverter valve and a Three Way Diverter Valve for diverting material into the various lines of weighing and bagging.

An Automatic Gross Weighing Machine with Heavy Duty Double Head Stitching Machine Synchronized with a Belt Conveyor is provided. Dust Collection System is supplied to collect dust from the entire system & plant.

This Complete System is fully automated with a PLC, Micro-Processor Based Controller and Instrumentation.

# INDUSTRIES

## Chemical & Petrochemical, Powders, Rice & Grains

We have supplied complete Weighing and Bagging System to M/s Emery Aekyung through Thyssenkrupp-Uhde as consultants.

The system consists of both types of bagging- Jumbo and Small Bagging. Diverter Gates convey the material to both hoppers through chutes. Level Sensors are provided in Feed Hoppers to maintain the material level in the hoppers.

Below the first Hopper, a Jumbo Bagging Machine is placed, and powered roller conveyors convey the filled jumbo bags to their destination.

The smaller bagging machine is placed under the second hopper. The small Bagging Line consists of Gross Weighing machine, Auto Bag Placer, Belt Conveyor, Auto Guiding Arrangement, Online Heat Sealing and Stitching Machine, a Bag Tilting and Turning Conveyor to change the orientation of the bag, Online Check Weigher, Online Metal Detector and Automatic Online Rejection System. This System is completely Automatic to maintain high accuracy. Bag Flattener arrangement with Hydraulic Compactor is provided to achieve flatness of bags on pallet. Post Bag Flattener, the bags on pallet are wrapped by automatic Wrapping Machine.

This complete system is fully automated with a PLC, Micro-Processor based Controller and Instrumentation.

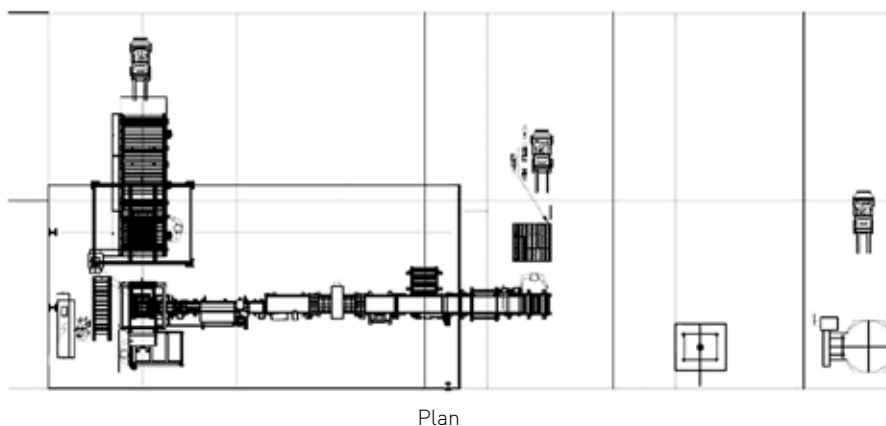
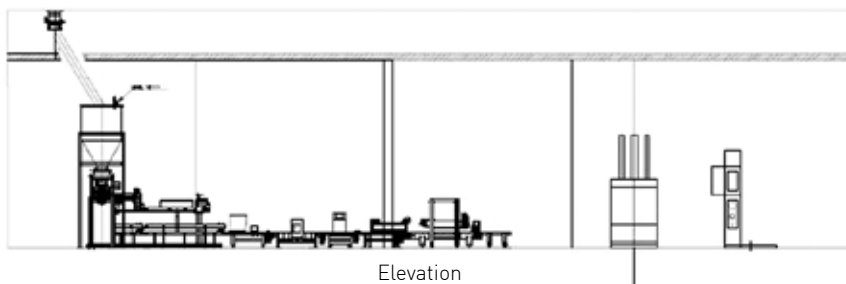





## JB Series - Fully Automatic Weighing & Bagging Machines

The JB series bagging machines are a recent addition in the evolution of the latest bagging technology applied to open mouthed pre-made bags.

With a heavy duty conception and construction, the most advanced materials are used for a fully automated processing, guaranteeing maximum reliability and minimum maintenance with minimal downtimes. These machines are directed to solving problems in dusty environments, with high accuracy and advanced automation complementing high autonomy requirements.



### User Friendly, Reliable Flexible and Fast

Functionality:

- Individual bag pick-up
- Automatic transfer of the empty bag to the filling spout without opening the gusset
- Full sealing of the bag mouth against the filling spout to prevent dust spreading
- Automatic bag filling with net Weigher or gross feeding
- Automatic bag transfer to the closing station by supporting the bottom and top side of the bag
- Bag closing with stitching and/or sealing

Suitable for applications with Plastic granules, PVC in suspension, Pellets, Salt, Fertilizers, Pet food, Beans, Seeds.

With adequate tooling including product de-aerator/compactors, these can operate with very fine powders to increase bulk density and reduce bag size.

### User Friendly, Reliable Flexible and Fast

Suitable for applications with Plastic granules, PVC suspension, Pellets, Salt, Fertilizers, Pet food, Beans, Seeds. With adequate tooling, these can operate with coarse powders in application involving a mix of cement, sand and gravel.



# PACKAGING SOLUTIONS

## Multihead Weigher, mixing of three separate products



## Online Heat Sealing

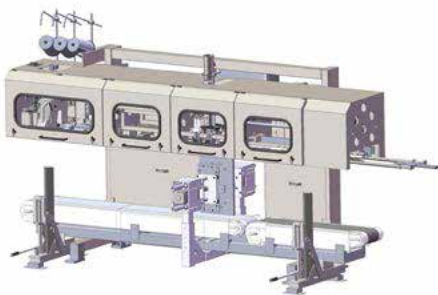

The bag closing line VELOMAT is applicable to all types of bag closing mechanisms. It can close bags in continuous or standstill process.

For product compaction the bag may either be pressed, vibrated or air-evacuated.

## Bag Closing Systems



### Sewing

Conventional sealing of bags. Possible to remove air from the bag, before and after sewing by folding the top edge of the bag or by applying an over tape closure.



### Ultrasonic or thermal welding Heat Sealing

### Combination with other closing systems



The FTS closure (Fold, Tape, Seal)



The pinch-top closure

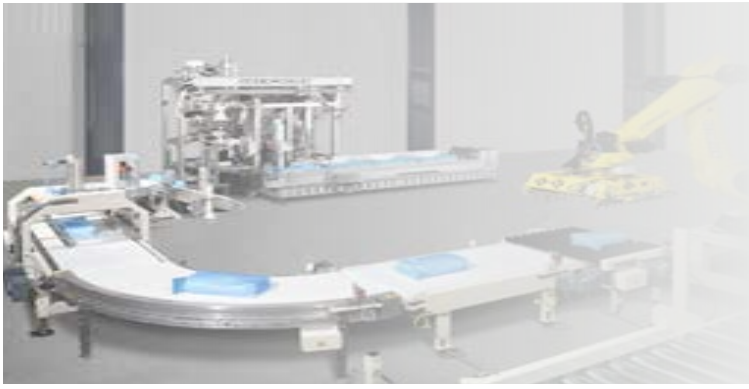

## New Automatic Valve Bag Packer



### **Automatic bag placer**

Suitable for: Cement, Dry grout, Calcium Carbonate, Calcium hydrate, Tile glue, Gypsum, Micronized sand, other construction powders.

Can handle varying bag and valve widths for paper and plastic bags without any adjustments being necessary. Range of Bag lengths from 380 to 900 mm and bag widths from 380 to 700 mm.

Each valve bag placer system includes an empty bag magazine, optionally available with bag singling for label application.



# PACKAGING SOLUTIONS

Special tasks call for special equipment – or additions

## JB Series - Valve Bagging

It provides a reliable closure, immediately after filling. It ensures that no dust can escape at discharge or further transport of the bag. The ultrasonic welding is applicable for paper and plastic bags and is safe in dust extraction areas.



## Pneumatic packer

Filling of light and powdered media ranging from 30  $\mu$  to 5 mm.

- Weighing ranges 10 – 30 kg / 12.5 – 50 kg.
- Up to 350 to 400 bags/h per packer unit, up to six in-line packers.

### Options

Automatic control of conveying air, own air compressor and flexible lining.



## The Mobile Version

Sometimes it makes more economic sense to move the filling Station to the silo instead of installing costly product supply system.

All additional equipments like compressors for conveying air, filters for the exhaust system, control Cabinets etc. are mounted on the mobile unit to give you complete flexibility, by simply positioning the filling plant wherever needed.





## Warehouse and Traffic Management System

JEPL provides automated conveyor systems for assembly, manufacturing, and distribution applications ranging from simple sections of gravity conveyor to a sophisticated computer-controlled system.

## JB Modular Conveyor System

JB Modular Conveyor System is a totally integrated package conveyor technology. Offerings include solutions for handling Drums, pouches, boxes, trays, poly bags or parcel envelopes.

Benefits of Automated Conveyor Systems:

- High performance and quality
- Accumulation without line pressure
- Reduced handling costs for repetitive tasks
- Merging and diverting for balanced workload
- Efficient movement of products between processes
- Integrated material flow controls supported by the latest technology



# WAREHOUSING SOLUTIONS

## Warehouse Management System

JB Warehouse Management System is a user configurable and a cost effective supply chain execution solution that improves labor productivity, eliminates human error, lowers shipping and inventory carrying cost. By harnessing the power of the Internet, this solution provides real time fulfillment visibility, speed and order accuracy to maximize customer loyalty.

- Powerful, Integrated, Flexible and User Friendly
- Vendor Managed Inventory (VMI)
- Seamless integrated with ERP and with Sales and Distribution systems
- Precision delivery
- Improve fulfillment Cycle Time
- Wireless, Internet and Internet enabled
- Optimize the flow of goods and information across your enterprise
- Support for all users, from forklift drivers to warehouse managers to executive decision markers
- Web based integration





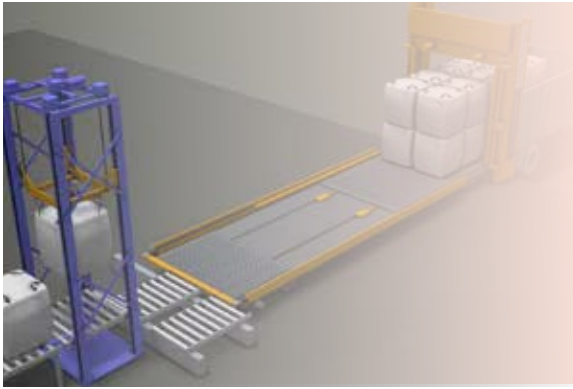

## Jumbo bagging - Gross Weigher

### Efficient filling of flexible IBCs

FIBC (Flexible Intermediate Bulk Container), also known as Big Bags, are economically and environmentally reasonable large size packages for storage and shipment of bulk solids.

A pivotal point in the economically beneficial use of FIBC is the decision for best suitable filling technology.



## Jumbo Bagging - Net Weigher

The base model can be supplemented for meeting miscellaneous filling and handling requirements. In addition to this, various functions can be automated, thus leading to an increase in filling performance at large.





# BULK PACKAGING SOLUTIONS

## Automatic Jumbo bagging

The FIBC – filling systems can also be used for filling Octabins



The mobile station is ideal for applications just where it is needed. The system is suitable for docking in several silos



With the double station you may increase performance and flexibility and streamline the workflow



With the supply of empty pallets and the removal of full FIBCs, an Automated pallet transport increases the efficiency of the system





### JB Serve Three Load Cell based Weighing & Bagging

This Machine can be offered for sites where following requirements are met:

- a) Minimum headroom of approximately 3.8 Meters is available
- b) Product is granular with lesser fines
- c) Product is reasonably free flowing
- d) Bulk Density of the powder is not lower than 600 m<sup>3</sup>
- e) Speed requirement is upto 20 bags / min

#### Features:

- a) Standard Capacity 50 Kg. It can be set for weighing from 20 Kg to 50 Kg
- b) This also can be set for weighing beyond 50 Kg with multi-dump operations

Bagging Rate & Accuracy depends upon bulk density, flow characteristics of the product and the Electronic Controller. Operations of this Machine are controlled by following High Speed Electronic Controllers and Load Cell Signals:

- a) **JB 07:** Can be applied for very high Bagging Speed\* of 12-15 Bags/Min. with accuracy of 0.05 to 0.1% per Sigma
- b) **JB 09:** Can be applied for Low Bagging Speed\* of 10-20 Bags/Min. and the accuracy of 0.05 to 0.1% per Sigma based on free flow material characteristics

#### Notes:

The machine can be offered for critical operations with various feeders in the following conditions.

- 1) The Product should be dry
- 2) When discharged from the weigh pan the dusting of the product should be negligible
- 3) The product should not be sticky

\* Bagging Rate and accuracy are for reference only



### UBM 85 - Single load Cell Bagging

The UBM Hopper Weighing systems can be offered where FIBC Bag filling in single dump is required. However, this machine can not be offered as a combo for 25 Kg/50 Kg and 1000 Kg weighing in a single machine.

This system consists of bigger feed gates to fill larger weighments in a single filling. Weighing is done in a Bigger Hopper (as per the required size of weighing). Vessel is fitted with a Knife Gate Valve for discharge of the material. Lugs of the vessel are fitted with 4 numbers of Sheer Beam Load cell Assemblies. Capacity of the Load Cells is designed as per the requirements. Feed gates are fitted just above the top of the vessel. Material of a set value is fed through the Feed Gates into the Vessel. Weighing value is settable as per the design. Size of the vessel depends upon the customer's requirements.



# WEIGHING SOLUTIONS



## High speed Gross Weigher

This Machine can be offered for sites where following requirements are met:

- Minimum headroom of approximately 2.5 Meters is available
- Product is granular with lesser fines
- Product is reasonably free flowing

### Features:

It can be set for weighing from 20 Kg to 50 Kg.

Bagging rate & accuracy depends upon bulk density, flow characteristics of the product and the Electronic Controller. It can be applied for Bagging Speed\* of 4-5 Bags/Min. with accuracy of 20 to 50 grams/Sigma for weighing bags

### Notes:

The machine can be offered for critical operations with various feeders in following conditions.

- The Product should be dry.
- The product should not be sticky.

\* Bagging Rate and accuracy are for reference only.

## Pre Weighing Equipments

### Bin Activator

A Bin Activator is required for the material that has bridging property, during operations. The Bin Activator breaks bridges formed inside the feed hopper. Thus helps the material to flow freely during Bagging Operations. Bagging Rate and accuracy is not hampered much in such installations. The Bagging Rate remains to 10 to 15 Bags/Min. and accuracy remains in the range of 20 to 50 grams/Sigma.



### Belt Feeder

The Belt Feeder is required where the material is in granular form but the flow of the material becomes sluggish due to the high percentage of fines in the product. At certain old fertilizer plants the Belt Feeder is required to maintain the shape of granules. However the Bagging Rate drops down to 3 to 4 Bags/Min. and accuracy also goes down to 50 to 70 grams/Sigma.

### Rotary Air Lock Valve

The rotary Airlock Valve is required for certain Salt Powders, where the material is not so free flowing and shape/size of the product is not important. In such installations the Bagging Rate comes down to 3 to 4 Bags/Min. and accuracy also comes down to 50 to 70 grams/Sigma for 50 Kg weighing.



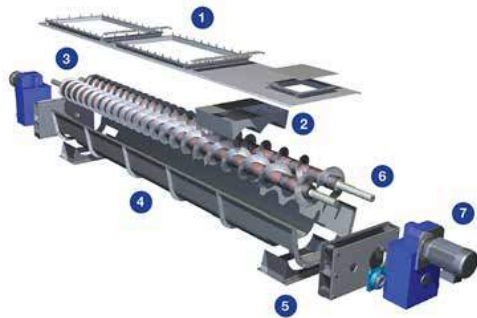

### Twin Screw conveyor

Twin Screw conveyors are generally required to handle sluggish fine powders. The pitch of the screw increases towards discharge end. This helps fluidization of the material and improves flow-ability of the product. In such installations the Bagging Rate comes down to 3 to 4 Bags/Min. using Twin Screw conveyor while accuracy comes down to 50 to 70 grams/ Sigma for 50 Kg weighing.

### Densify Screw Feeder

The Densifying Screw Feeder is offered where the product to be bagged is fluidized. Density of such material is very low owing to entrapped air in the product. Such products are very difficult to handle owing to highly free flowing characteristics of the product. Due to low density of the product and high quantity of entrapped air, such products require bigger size of bag to accommodate the given weight of the product. The densifying screw feeder removes entrapped air from the product. Density of the product thus increases sufficiently enough to accommodate this material into the given size of the bag. However some percentage of air still remains inside the product which controls the flow-ability of the product.

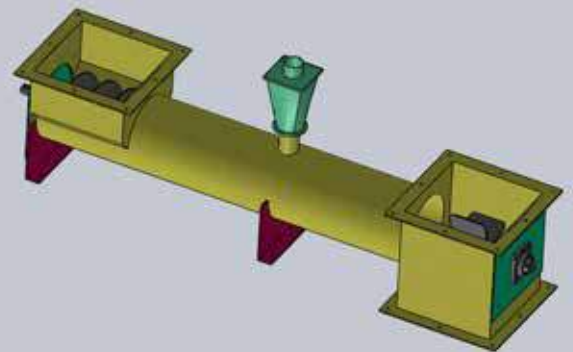

### Gravity Metal Detector with Rejection Valve

At certain sites, pre-weighing metal detection is required by the user. This type of Metal detector is installed in line with a Feed Chute. An electromagnetic coil surrounding the non-metallic body of this equipment is used for detection of metal present in the material. At bottom of the equipment a diverter valve is fitted to divert the rejected part of the material into a small piece of rejection chute. When the material with presence of metal passes through this part of the feed chute, the metal is detected and the diverter valve is activated to divert this part of the material to the rejection chute. The diverter valve comes back to its normal position when the contaminated material is delivered to rejection chute. The equipment then starts feeding the material to the weighing machine normally. The rejected material is collected in a container below the rejection chute.



# PRODUCTS

## Post Weighing Equipment

### Automated Bag Placer

- Automatically opens and places paper, plastic and poly woven open mouthed bags on to the bag filling scale
- Fully adjustable to different bag sizes without tools in less than one minute
- Placing speeds up to 20 bags/minute
- Can be easily integrated with existing bag filling scales
- Fully assembled and tested in our factory prior to shipment

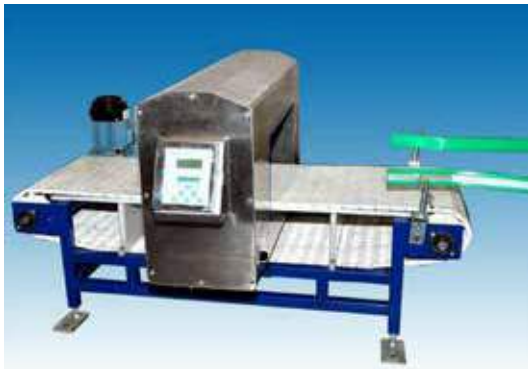

### Metal Detectors with various Applications

Metal detector detects metal in a filled bag when the bag passes through its electro-magnetic field. When metal is detected in the bag passing through the metal detector, the same is rejected by the bag rejection system ahead of the metal detector. Such bags slide down the non-driven roller conveyor. Metal free bags are transferred to the next system without any stoppage.

### Motorized Diverter

Motorized diverters can be offered where there is a requirement for transfer of filled and stitched bags to another conveyor at an angle approximately 120 degrees with the main conveyor. This can also be used in the Rejection System. The more the angle the better the transfer. The motorized diverter consists of the following parts:

- a) Geared Motor (Vertically mounted)
- b) Frame and pulleys for belt operations
- c) Pneumatic Mechanism for Diverter operations
- d) Fixing and Angle adjustment mechanism
- e) Belt

The belt moves towards the delivery side. In case of accepted bags, the pneumatic mechanism of the diverter remains parallel to the rejection conveyor allowing the bags to transfer to the next device. If the bag is rejected at previous device then the pneumatic mechanism turns into the path of the rejection conveyor and the bag is diverted out of the conveyor.



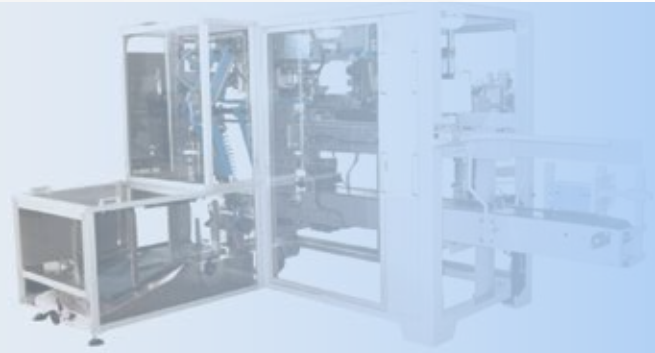

## Bag Flattener



The flatteners are required for palletizing operations where the filled bags are pillow shaped and cannot be stacked properly during palletizing. There are two major types of Flatteners.

- 1) A Spring Loaded drum above the Flattener Belt: The drum is hung from the top supported by two springs and pressurizes the bag. The drum is lifted up with the springs if the pressure on the bag is more than required. This protects the filled bag passing through this part of flattener. The height of the drum from the flattener belt below can also be adjusted for optimum pressure on the filled bags
- 2) A motorized belt conveyor: Conveyor is hung from the top frame above the Flattener Conveyor by four movable links. Any extra pressure exerted on the bag is taken care of by these movable links



### Fully Automatic Downstream Systems

The system consists of following arrangement from Right to Left.

- 1) Bag Tilting and Turning Device
- 2) Metal Detector
- 3) Check-Weigh System
- 4) Motorized diverter mechanism for Bag Rejection
- 5) Bag Flattener

## Gantry Palletizer

It is a low cost palletizer. The same can be offered for low Palletizing speed of 4 Bags/Min. It works on 3 Axis and controlled by Stepper Motors, Photo-electric sensors and pneumatics. The Pick and Place operations are configured by the PLC Logic. Number of bags per layer and total number of layers is limited to 6 layers in a standard version.



## Robotic Palletizer

The Robotic palletizer is a sophisticated and costlier version. It works on 6 Axis and controlled by Servo motors for perfect accuracy and high speed of the operations. Speed of this palletizer is in the range of 18 to 22 bags/minute. The same can be offered for sophisticated automatic and high speed bagging lines.



Technology Partner



# PRODUCTS

## Pallet Wrapping

Wrapping Machines are used to keep bags on the pallet intact with the pallets. Certain hygroscopic material, when filled in the bags requires stretch film wrapping to preserve the material during storage or overseas shipments. Auto Pallet wrapping machines can be offered for such requirements.



## Dust Collecting System



Dust collecting systems can be offered to maintain the bagging area/plant, free of dust. This system is designed as per the number of machines and overall bagging equipment.

## Conveyors

Various types of conveyors can be offered as per the customers or project requirements.



# SMART ELECTRONICS

## Weighing & Bagging Controller Model – JB 07



### Features

- Integrated with Unique technique & dedicated to handle the complete weighing & bagging system with high speed & price accuracy
- Facility of interconnectivity with any PLC or instruments through various types of in-built protocol
- On-Site Performance Certified by DNV
- OIML R 63 Approved (International Organization of Legal Metrology)
- I/O status, actual value, set value, bar graph, commands, Recipe name etc. are displayed in run screen
- All I/O fully customized
- Single & compact unit
- Accuracy – 20 g/sigma
- 24 bit ADC
- 1600 readings/second
- Auto Inflight Correction to get best consistent accuracy
- Machine will stop when accuracy is out of limit, material will discharge only after acknowledgement of alarm
- Top up feeding from HMI/Operator panel in case of underweight
- I/O test page for quick trouble shooting
- Auto tare facility to get best possible accuracy
- Manual tare from operator
- System pause facility
- Batch wise operation
- Cumulative Totalizer for each recipe
- On line bag counter
- Feeding Interlocks with material level & air pressure to reduce material rejection
- Color touch screen with necessary data displaying on run page
- Optional key board for hazardous location
- On line printer, PC, PLC connectivity
- USB data logging with date & time stamp
- In-built trouble shooting guide
- Multi-layer passwords
- Settable soft filters to reduce environmental vibration impact
- 256 Preset recipes for quick interchange of weighment size
- Audio visual machine status
- Wired/wireless serial printer
- Wired/wireless Remote display for KPI (key performance indicators)
- Data logging software for single/multiple (max 16) JB 07
- Wireless connectivity between machine & panel
- USB data logging module for pen drive/ USB drive
- GSM /CDMA module for fault SMS facility
- In-built RS 232, RS 485, Ethernet, USB port
- 100 – 260 VAC, 50 Hz Universal power supply
- System Control voltage 24 VDC for human safety
- Conformal Coating on PCB (LOCTITE 3900)



# REFERENCES

## Reference List

References	Fertilizers	NFL	Hindustan Fertilizer	VSP
		RCF	Deepak Fertilizers	SAIL
		FACT	EID Parry	Paradeep
		GNVFC	GSFC	Transworld
		Zuari Agro	Sanderson	Aeries Agro
		Corromondel	MFL	KRIBHCO
		IFFCO	Maha. Agro	Emirates Bio.
	Chemical and Petrochemicals	Reliance	P & G	Aarti Indus.
		BASF	Gharda Chemical	NOCIL
		Godrej	Alfa Laval	Birla Cellulosic
		GHCL	Rallies	Colour Chem.
		UPL	Bayer	Pesticides India
		Atul	Grasim	Transpex Silox
		Sandvick	HEG Ltd.	Araldite
		Food (Seeds & Grains)	Andhra Sugar	KRBL
	DCW		Thermax	NHEC
	Cadbury		Picric	Dutta SSK
	Marico		Cottor Plants	KCP Ltd.
	Ruchi Soya		Mother Dairy	Godavari Sugar
	Hindustan Lever		GHCL	Krishna SSK
	Mysore Paper		Barmalt	Kothari Sugar
	Animal Feed		Venky's	Shanathi Poultry
		CP India	SKM	Avitech
		Godrej Agrovet	Vimla	Kaveri's Bio
		Sampoorna Feed	Amrit Group	Chareon

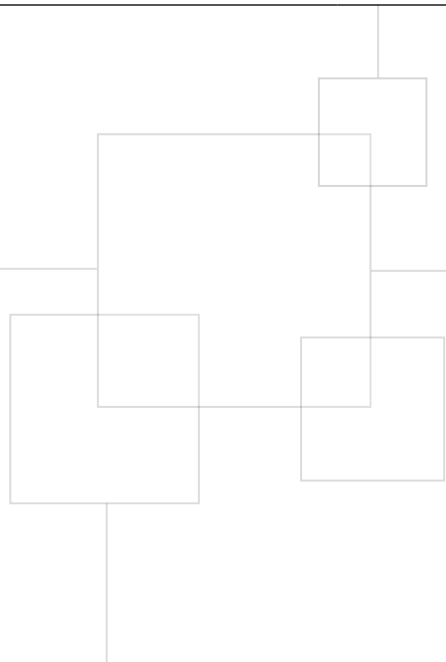

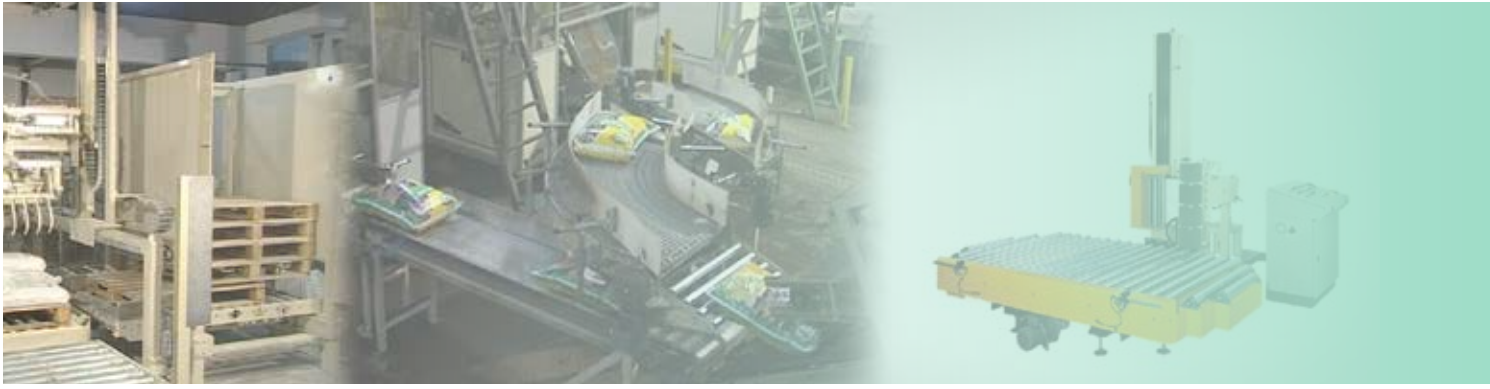

## Service Advantages

- Erection and commissioning of machine.
- Customer trainings during commissioning
- After sales service
- Annual Maintenance Contracts
- Telephonic Support to attend the problems
- Supply of Spare parts
- Suggestions to modify the machine operations as per the customer's requirements
- Deputation of engineers on priority during emergency

## Training

- Periodic customer and employee training
- Schedule of training is conveyed to the key customers one month in advance

# SERVICES

## Our Presence

With more than 300 employees spread over 5 locations in India and overseas and more than 7000 Installations across the globe, we are virtually omni present to service all your material handling needs.



### Service Offices in India

Ahmedabad  
New Delhi  
Chennai (Madras)  
Mumbai (Bombay)  
Hyderabad

### Engineering Centers in India

Ahmedabad

### Service Offices in Middle East

UAE  
Qatar  
Oman

## Our Three Vital Commitments

**CARE** - Customers Are Really Everything

**COIN** - Continuous Improvements are Needed

**TRAC** - TRaining Accomplishes Competence

### DIVISION OFFICE

64/a, GIDC Industrial Estate,  
Phase -1, Vatwa,  
Ahmedabad - 382445,  
Gujarat, India.  
Tel.: +91-79-49003636/3737  
Fax: +91-79-25831825  
Email: mhd-sales@jasubhai.com

### CORPORATE HEAD OFFICE

26, Maker Chamber VI, Floor II,  
Nariman Point,  
Mumbai - 400 021  
Maharashtra, India  
Tel: +91-22-40373737  
Fax: +91-22-22870502  
Email: mumbai@jasubhai.com

### REGIONAL OFFICES

#### Mumbai

110, Thacker Tower, Plot No. 86,  
Sector 17, Vashi,  
Navi Mumbai - 400 705,  
Tel.: +91-22-42136300/  
Fax: +91-22-42136399  
Email: sales\_ces@jasubhai.com

#### New Delhi

803, Chiranjiv Tower,  
Nehru Place,  
New Delhi - 110 019, India.  
Tel: +91-11-46745555  
Fax: +91-11-26427404

#### Vadodara

202, Concorde, R. C. Dutt Road,  
Alkapuri, Vadodara - 390 005,  
Gujarat, India  
Tel: +91-265-2352647  
Fax: +91-265-2337189

#### Kolkata

44/B Creek Row, Ground Floor,  
Kolkata - 700 014  
Mob: +91 90380 57380  
Tel: +91-33-22317344 / 7346  
Fax: +91-33-24420176

#### Chennai

Jhaver Plaza, 1<sup>st</sup> floor, 1-A,  
Nungambakkam High Road  
Chennai - 600 034,  
Tamil Nadu, India  
Tel: +91-44-42327728

#### Oman

Jasubhai Engineering Muscat LLC  
Shed No 4B, Building No 1176  
Plot No 1156, Way No 5222  
GHALA Industrial Area  
Muscat, Oman

### MANUFACTURING FACILITIES

64/a, GIDC Industrial Estate,  
Phase-1, Vatwa,  
Ahmedabad - 382445,  
Gujarat, India.  
Tel: +91-79-49003636  
Fax: +91-79-25831825

Jasubhai International FZCO  
FZS2 AC01,  
P O Box: 18403, Jebel Ali,  
Dubai, UAE.  
Tel: +97-148860704 / 8862991  
Fax: +97-148860705

Website: [www.jasubhaiengineering.com/mhd/](http://www.jasubhaiengineering.com/mhd/)

